

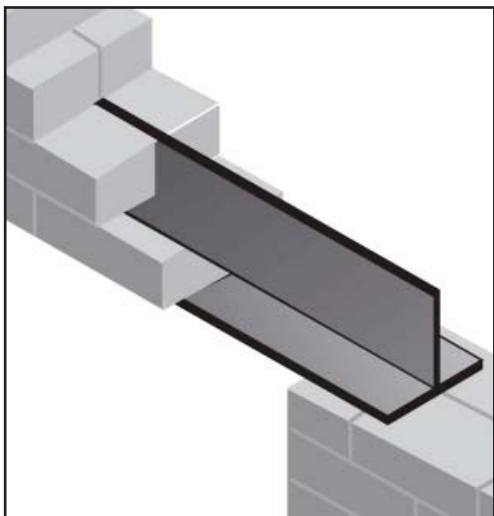

LINTELS

SOLID WALL TS LINTEL



LENGTHS AVAILABLE

600mm
 1800mm
 1950mm
 2400mm
 2550mm
 2700mm
 2850mm
 3000mm
 3150mm
 3300mm

APPLICATION:

For use in SOLID 225mm or 200mm construction, facing brickwork both sides. Can be supplied with plaster key if required.

TO SPAN:

300mm to 2400mm. When ordering, specify lintel name and overall length.

SPECIFICATION:

L.A. (Mild Steel) is manufactured from hot dipped BS EN 10142: 1991, DX 51D+Z275 G600. L.A.ss is manufactured from Stainless Steel to BS 1449: Part 2:1975. Grade 304 S15.

Eliminates cold bridges. Used in timber frame, traditional and refurbishment. The Lintel Angle does not need to be fixed to the inner leaf. It should be propped during construction if more than 1800m long.

THE LINTEL ANGLE IS AVAILABLE INTWO VERSIONS:

L.A. (Mild Steel) galvanised and painted, or L.A. stainless steel.

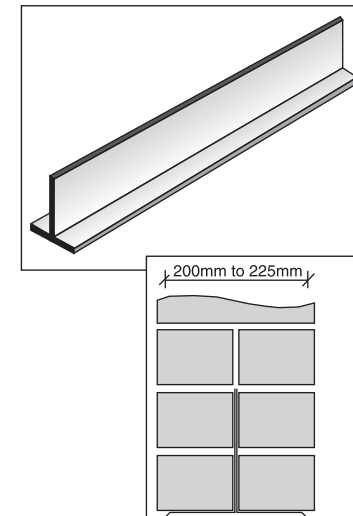

Reference	T.S.				
Lintel Lengths (available in increments of 150mm)	600	1950	2550	2850	3150
	1800	2400	2700	3000	3300
Height (H) (mm)	119	158	215	215	215
Allowable Safe UDL (kN)	10.0	15.0	20.0	20.0	15.0
Zx-x (cm ³)	11.1	18.8	33.3	33.3	33.3
Lx-x (cm ⁴)	93	201	462	462	462
Allowable Moment (kNm)					
Max.Web Buckling at Supports (kN)					
WEIGHT PER METER (KG)	10.6	12.6	15.6	15.6	15.6



Galtee Valley Enterprise Park, Ballylanders, Co. Limerick
 Tel: 062 46290, Fax: 062 46291, E-mail: info@batmetalwork.com

www.batmetalwork.com