

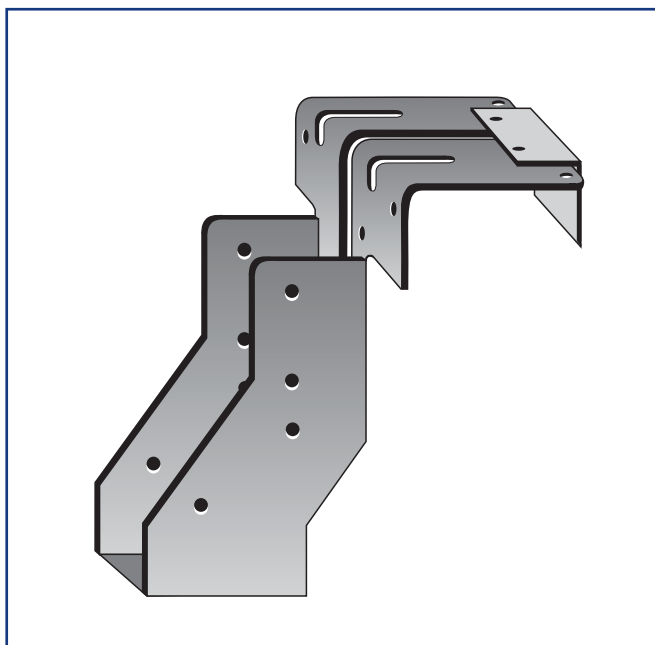

JOIST HANGERS

O.P.H. TYPE R (RETURN) please supply joist depth, width and block size



DESIGN FEATURES

Masonry flange has greater bearing area than 'Z' type hangers.

Material thickness, including protective coatings 2.5mm

CORROSION PROTECTION: G275 (275 gms / mm sq)

Zinc galvanising including both sides

Non-welded construction

Manufacturing from pre-galvanised mild steel

BS EN 10142: 1991, DX 51D+Z275

HOW TO ORDER / SPECIFY BAT O.P.H. JOIST HANGERS

Please state dimensions

Type 'S' (A) Joist depth (B) Joist width

Type 'R' and 'ST' (A) Joist depth (B) Joist width

(C) Thickness of masonry in which it is to be used

Intermediary depths are available on request for all types of O.P.H. Joist. Hangers and are priced to the nearest above size.

NOTE: Unless requested, the internal Joist Hanger depth of BAT Joist Hangers 150mm or over is 10mm less than the actual joist depth to accommodate notching of the joist if required.

TIMBER DEPTH (mm)	HANGER DEPTH (mm)	JOIST WIDTHS (mm)
130	130	38/44/51/63/75/100
150	140	
175	165	
200	190	
225	215	
250	240	

Joist Depth (mm)	Internal Joist Hanger depth (mm)	Joist width (mm)			
		38	44	50	75
150	140	Capacity (kN)			
		17.5	12.8	11.6	13.6
175	165	15.6	12.6	12.6	14.5
225	215	12.6	12.2	14.1	15.6



Galtee Valley Enterprise Park, Ballylanders, Co. Limerick
Tel: 062 46290, Fax: 062 46291, E-mail: info@batmetalwork.com

www.batmetalwork.com